

SAFETY & WARNINGS

1. Install in accordance with national and local electrical code regulations.
2. This product is intended to be installed and serviced by a qualified, licensed electrician.
3. Only use copper wiring. Use wires rated for at least 176°F (80°C) and certified for use with external connection of electrical equipment.
4. Tape light, attached wire leads, and additional extension cables, connectors, etc., are not rated for in-wall installation unless otherwise noted. Tape light and attached wire leads are field-cuttable.
5. Ensure applicable wire is installed between driver, fixture, and any controls in-between. When choosing wire, factor in voltage drop, amperage rating, and type (in-wall rated, wet location rated, etc.). Inadequate wire installation could overheat wires, and cause fire.
6. Do not install in environment where excessive heat may exist (ex. close proximity to fireplace, etc.) See Ambient Temperature ratings
7. Do not modify product beyond instructions or warranty will be void.
8. Actual color may vary from what is pictured on this sheet and other print materials due to the limitations of photographic processes.
9. We reserve the right to modify and improve the design of our fixtures without prior notice. We cannot guarantee to match existing installed fixtures for subsequent orders or replacements in regards to product appearance, CCT, or lumen output.

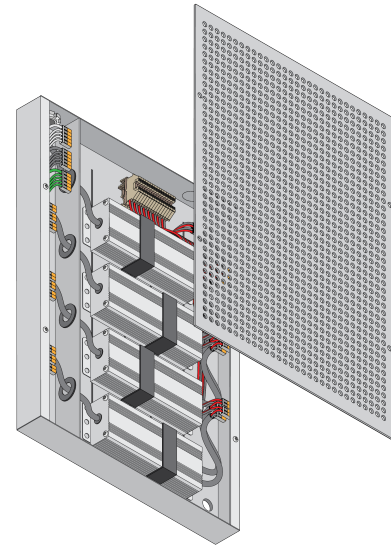

Contents

Step 0. Turn Power Off at Circuit Breaker pg. 2

(S) SURFACE MOUNT

Step S1. Mount Junction Box pg. 2

Step S2. Remove Knockouts pg. 2

Step S3. Connect AC Power Wires to Driver Inputs pg. 2

Step S4. Connect LED Fixtures to Output Terminals pg. 2

Step S5. Secure Junction Box Cover to Panel pg. 3

(R) RECESSED MOUNT

Step R1. Prepare Recessed Area pg. 4

Step R2. Remove Recessed Mounting Knockouts (4) pg. 4

Step R3. Secure Junction Box to Studs pg. 4

Step R4. Remove Knockouts pg. 4

Step R5. Connect AC Power Wires to Driver Inputs pg. 5

Step R6. Connect LED Fixtures to Output Terminals pg. 5

Step R7. Secure Junction Box Cover to Panel pg. 5

Tools For Install

Pencil

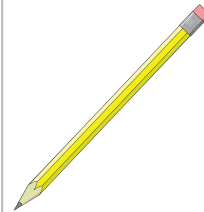

Ruler

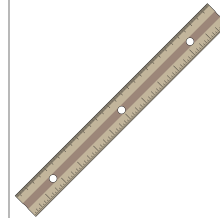

Phillips-head screwdriver

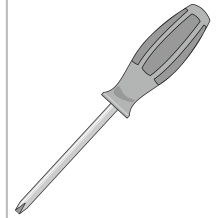

Pliers

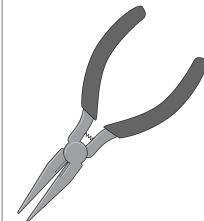

Power Drill

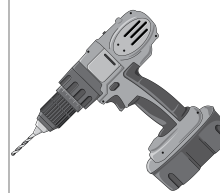

Strain Relief

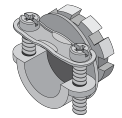

Wall Anchors

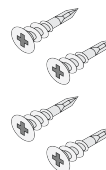

Screws



(S) SURFACE MOUNT

0. Turn Power Off at Circuit Breaker

Never cut wire attached to a live circuit.

S1. Mount Junction Box

Fasten Junction Box to surface using appropriate screws and wall anchors.

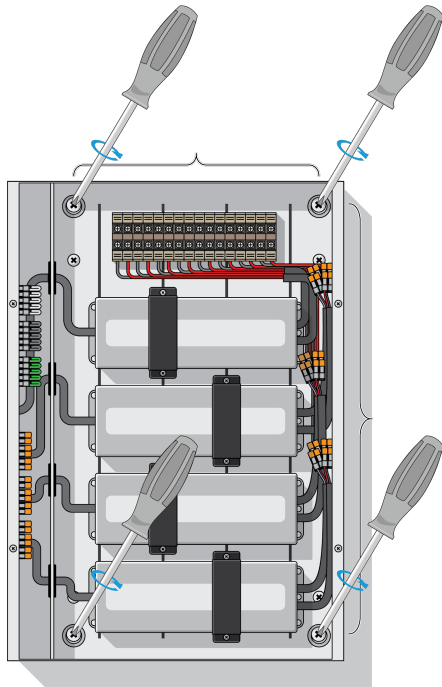

S2. Remove Knockouts

Use screwdriver and hammer to loosen knockout.

Grip knockout with pliers. Bend back and forth until broken off.

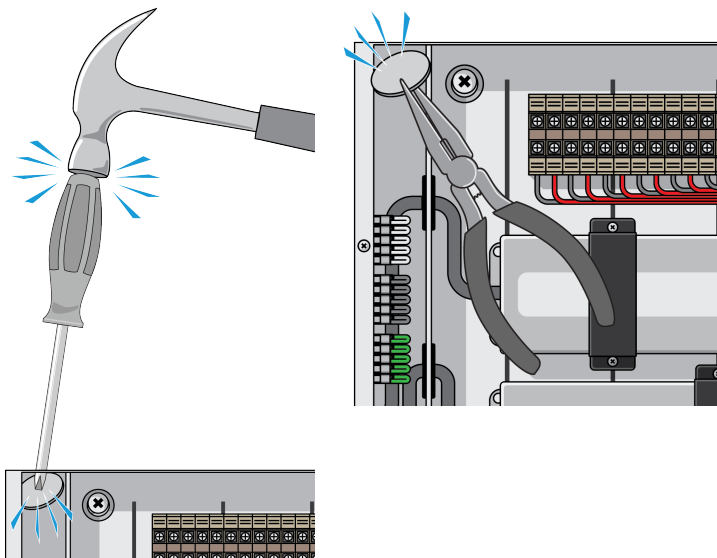

S3. Connect AC Power Wires to Driver Inputs

Fasten appropriate strain relief for 1/2 or 3/4 in. accessories.

Tuck wires back into Junction Box.

Pull input terminals from Junction Box, then strip AC power wires to a minimum of 0.45 in. before fastening to input terminals.

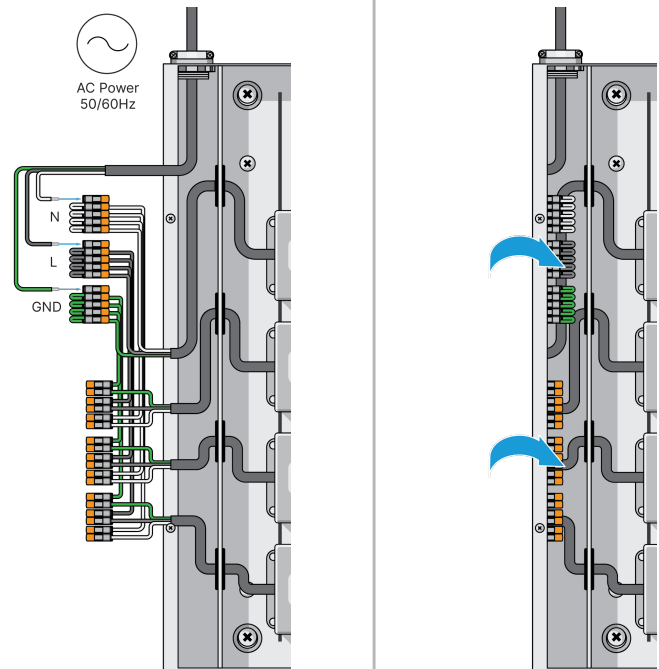

S4. Connect LED Fixtures to Output Terminals

Connect positive and negative wires from LED Fixtures to matching output terminals.

Terminal Block configuration and location is dependent on driver selection.

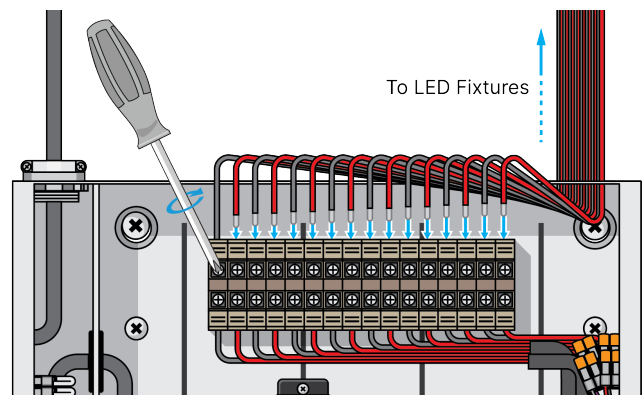

S5. Secure Junction Box Cover to Panel

Fasten Junction Box cover to Junction Box panel using included screws.

Do not obstruct ventilation holes.

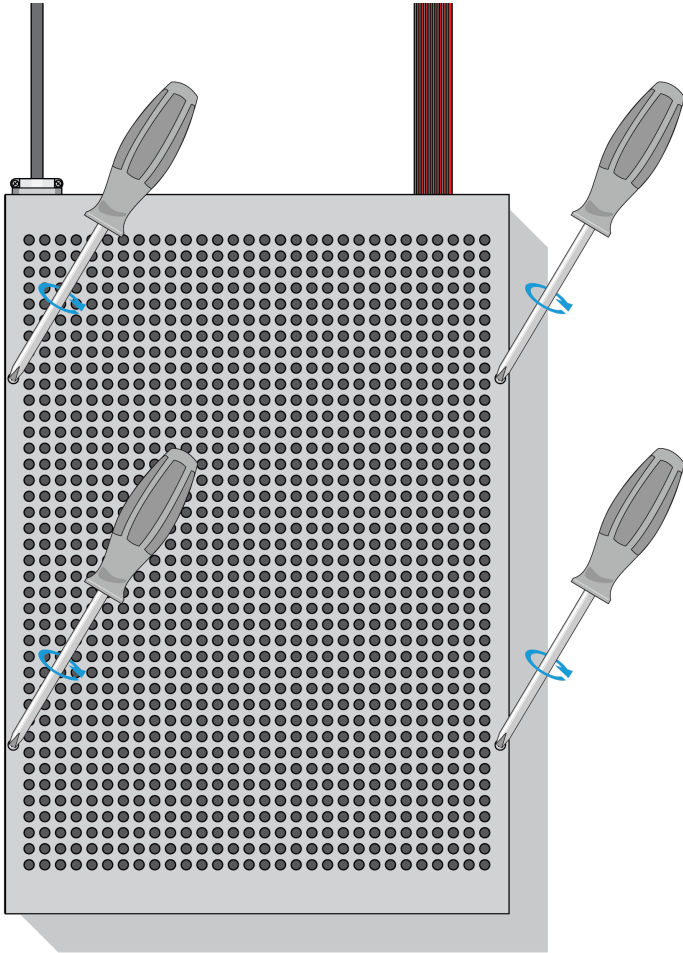

(R) RECESSED MOUNT

R1. Prepare Recessed Area

Prepare the 16 in. on center stud bay by ensuring you have a minimum of 14 in. wide x 18.75 in. tall area.

Cut out a recessed hole matching the dimensions of the Junction Box Panel Dimensions. 14 × 18.62 (W x L)

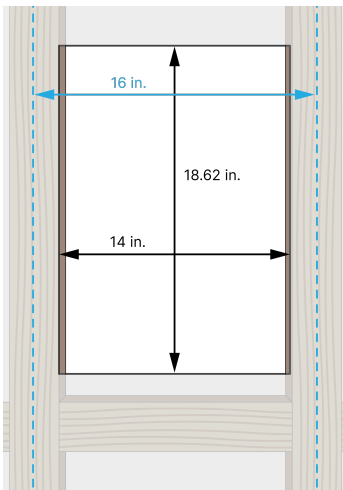

R2. Remove Recessed Mounting Knockouts (4)

Use screwdriver and hammer to loosen knockouts.

Grip knockouts with pliers. Bend back and forth until broken off.

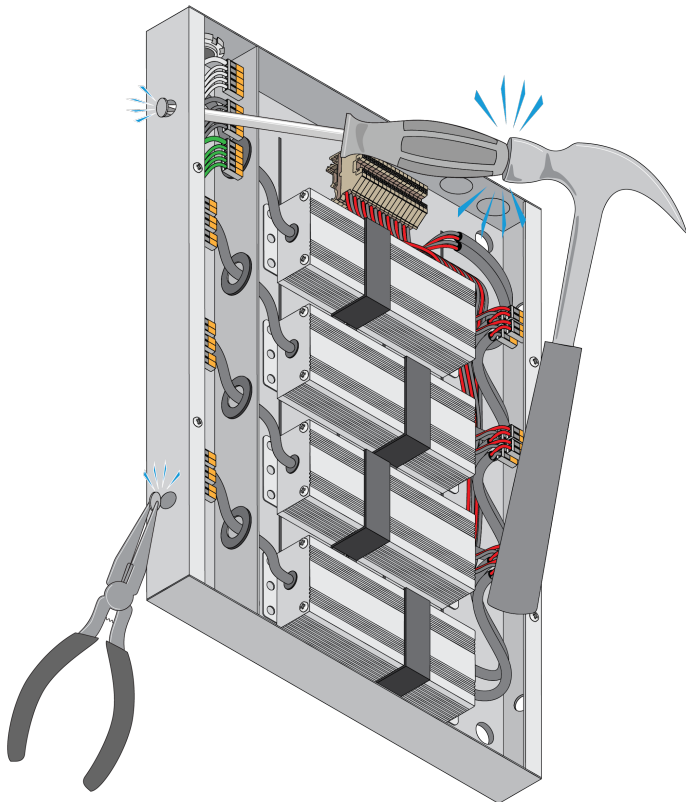

R3. Secure Junction Box to Studs

Secure Junction Box to studs with appropriate screws. Adjust to drywall depth prior to tightening.

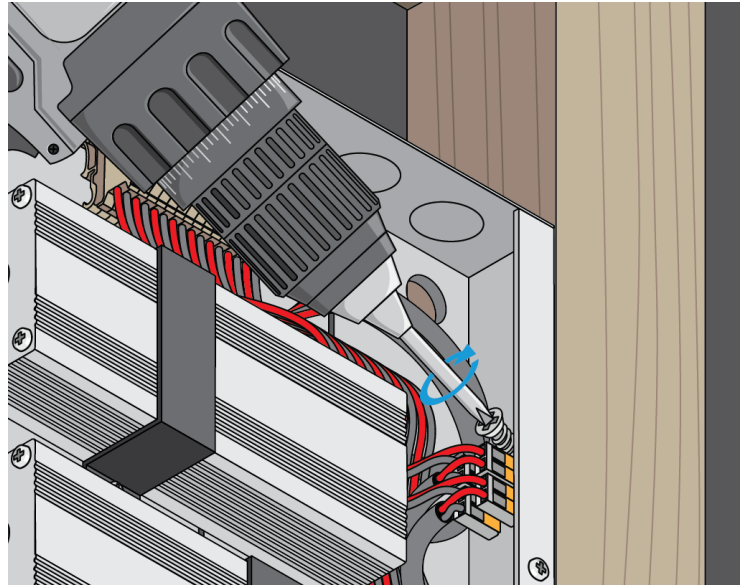

R4. Remove Knockouts

Use screwdriver and hammer to loosen knockout.

Grip knockout with pliers. Bend back and forth until broken off.

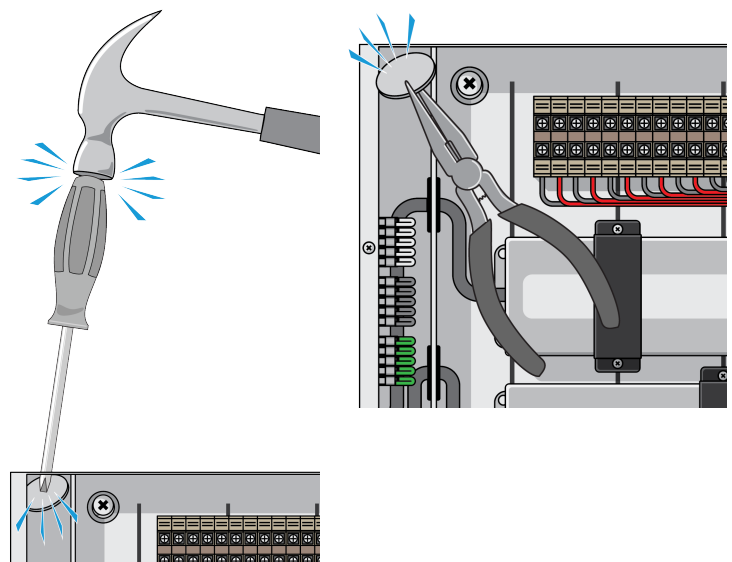

R5. Connect AC Power Wires to Driver Inputs

Fasten appropriate strain relief for 1/2 or 3/4 in. accessories.

Pull input terminals from Junction Box, then strip AC power wires to a minimum of 0.45 in. before fastening to input terminals.

Tuck wires back into Junction Box.

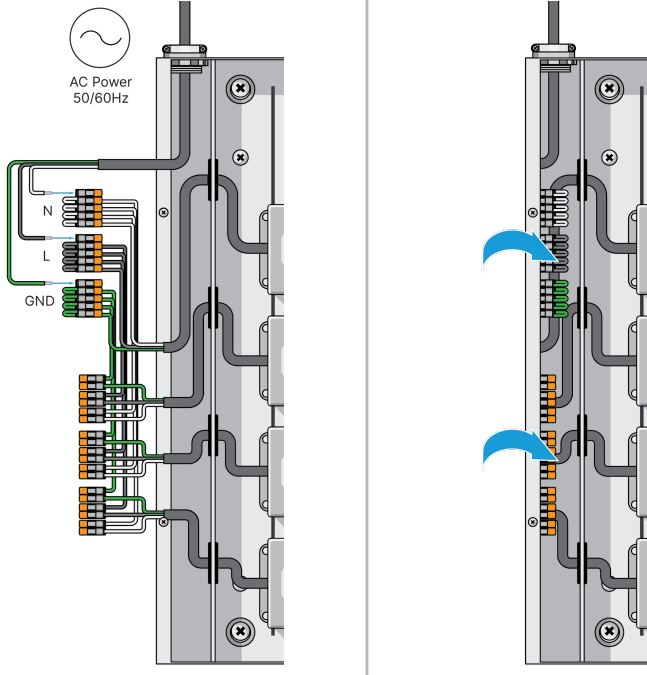

R6. Connect LED Fixtures to Output Terminals

Connect positive and negative wires from LED Fixtures to matching output terminals.

Terminal Block configuration and location is dependent on driver selection.

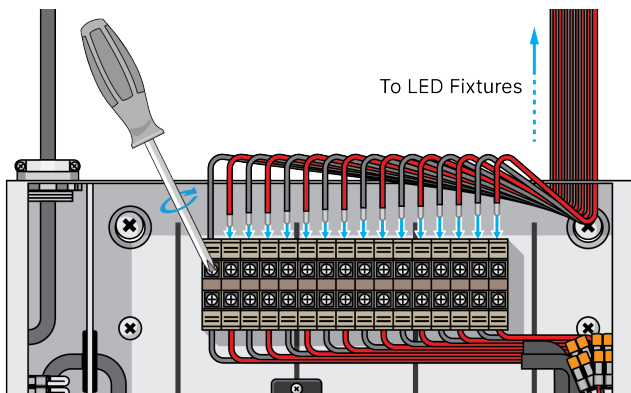

R7. Secure Junction Box Cover to Panel

Fasten Junction Box cover to Junction Box panel using screws.

